

Garage door opener

- IT - GUIDA RAPIDA
- EN - QUICK GUIDE
- FR - GUIDE RAPIDE
- ES - GUÍA RÁPIDA
- DE - KURZANLEITUNG
- PL - INSTRUKCJA SKRÓCONA
- NL - SNELSTARTGIDS
- RU - краткое руководство по установке



DEFAULT = OFF									
L1	IT	EN	FR	ES	DE	PL	NL	RU	
	Chiusura Automatica	Automatic closure	Fermeture automatique	Cierre Automático	Automatische Schließung	Zamknięcie automatyczne	Automatische sluiting	Автоматическое закрытие	
OFF	semiautomatico	semi-automatic	semi-automatique	semiautomático	halbautomatisch	półautomatyczny	semiautomatico	полуавтоматический	
L2	IT	EN	FR	ES	DE	PL	NL	RU	
	Richiudi Dopo Foto	Close After Photo	Fermeture immédiate après passage devant photocellule	Cerrar después de fotocélula	Schließen nach Durchfahrt der Photozelle	Zamknij po Foto	Hersluiten na foto	Закрыть после фотоэлемента	
OFF	il tempo di pausa è quello programmato oppure non c'è chiusura automatica	the pause time corresponds to that set or the gate does not re-close automatically	le temps de pause est celui programmé ou il n'y a pas de refermeture automatique	el tiempo de pausa es el programado o no hay recierre automático	Es gilt die programmierte Pausenzeit bzw. es erfolgt kein automatisches Schließen	czas trwania pauzy jest zaprogramowany lub nie ma automatycznego zamknięcia	de pauzetijd is de geprogrammeerde tijd of er is geen automatische hersluiting	время паузы представляет собой заданное время или же автоматическое закрытие отсутствует	
L3	IT	EN	FR	ES	DE	PL	NL	RU	
	Chiude Sempre	Always Close	Ferme toujours	Cerrar Siempre	Schließt immer	Zawsze Zamyka	Altijd sluiten	Всегда закрывать	
OFF	al ritorno dell'alimentazione il cancello rimane fermo	when the power supply is restored the gate keeps still	au retour de l'alimentation, le portail reste à l'arrêt	al retorno de la alimentación la cancela permanece detenida	Bei Rückkehr der Stromversorgung bleibt das Tor stehen	po powrocie zasilania brama pozostaje nieruchoma	bij het terugkeren van de stroom blijft het hek stilstaan	после восстановления подачи питания ворота остаются неподвижными	
L4	IT	EN	FR	ES	DE	PL	NL	RU	
	Stand-By	Stand-By	Stand-By	Stand-By	Stand-By	Stand-By	Stand-By	Stand-By	Ожидание
OFF	-	-	-	-	-	-	-	-	-
L5	IT	EN	FR	ES	DE	PL	NL	RU	
	Inversione lunga	Long inversion	Inversion longue	Inversión larga	Lange Reversierung	Długi ruch w przeciwnym kierunku	Lange inversie	Длительная инверсия	
OFF	l'inversione è breve, 15cm circa	inversion is short, approx. 15cm	l'inversion est brève, 15 cm environ	la inversión es breve, 15 cm aprox	ist die Reversierung kurz, ca. 15 cm	ruch w przeciwnym kierunku jest krótki, około 15 cm	de inversie is kort, ongeveer 15 cm	инверсия короткая, около 15 см	
L6	IT	EN	FR	ES	DE	PL	NL	RU	
	Prelampeggio	Pre-flashing	Préclignotement	Parpadeo previo	Vorwarnen	Wstępne miganie	Voorwaarschuwing	Предварительное мигание	
OFF	l'accensione del lampeggiante coincide con l'inizio manovra	the warning light starts flashing when the manoeuvre starts	l'allumage du clignotant coïncide avec le début de la manoeuvre	el encendido de la luz intermitente coincide con el comienzo de la maniobra	Das Einschalten der Blinkleuchte erfolgt gleichzeitig mit dem Bewegungsbeginn	włączenie lampy ostrzegawczej następuje równocześnie z rozpoczęciem manewru	het knipperlicht gaat aan bij het begin van de manoeuvre	мигающее устройство начинает мигать одновременно с началом движения	
L7	IT	EN	FR	ES	DE	PL	NL	RU	
	Sensibilità	Sensitivity	Sensibilité	Sensibilidad	Empfindlichkeit	Czułość	Gevoeligheid	чувствительность	
OFF	-	-	-	-	-	-	-	-	-
L8	IT	EN	FR	ES	DE	PL	NL	RU	
	Tipo Portone	Type of door	Type de porte	Tipo de puerta	Art der Tür	Rodzaj drzwi	Type deur	Тип двери	
OFF	per portoni di minori dimensioni	for smaller doors	pour les petites portes	para puertas más pequeñas	für kleinere Türen	dla mniejszych drzwi	voor kleinere deuren	для небольших дверей	

IT - Dichiarazione CE di conformità e dichiarazione di incorporazione di "quasi macchina" / EN - EC declaration of conformity and declaration of incorporation of partly completed machinery

Nota: il contenuto di questa dichiarazione corrisponde a quanto dichiarato nel documento ufficiale depositato presso la sede di Nice S.p.a., e in particolare, alla sua ultima revisione disponibile prima della stampa di questo manuale. Il testo qui presente è stato riadattato per motivi editoriali. Copia della dichiarazione originale può essere richiesta a Nice S.p.a. (TV) I. / Note: The contents of this declaration correspond to declarations in the official document filed in the offices of Nice S.p.a. and, in particular, the latest version thereof available prior to the printing of this manual. The text herein has been re-edited for editorial purposes. A copy of the original declaration can be requested from Nice S.p.a. (TV) I.

Numero dichiarazione: 245/SOON - Revisione: 9 - Lingua: IT - Nome produttore: NICE S.p.a. - Indirizzo: Via Pezza Alta N°13, 31046 Rustignè di Oderzo (TV) Italy - Persona autorizzata a costituire la documentazione tecnica: NICE S.p.a. - Tipo di prodotto: Motoriduttore elettromeccanico con centrale incorporata - Modello/Tipo: SO2000 - Accessori: Ricevitore radio mod. SMX, SMXS e ONEXI, batterie di emergenza PS124
 Declaration number: 245/SOON - Revision: 9 - Language: EN - Name of manufacturer: NICE S.p.a. - Address: Via Pezza Alta N°13, 31046 Rustignè di Oderzo (TV) Italy - Person authorised to draw up the technical documentation: NICE S.p.a. - Type of product: Electromechanical gearmotor with central incorporated - Model/Type: SO2000 - Accessories: Radio receiver mod. SMX, SMXS and ONEXI, emergency battery PS124.

Il sottoscritto Roberto Griffa in qualità di Amministratore Delegato, dichiara sotto la propria responsabilità che il prodotto sopra indicato risulta conforme alle disposizioni imposte dalle seguenti direttive: / The undersigned Roberto Griffa, in the role of Chief Executive Officer, declares under his sole responsibility that the product described above complies with the provisions laid down in the following directives:

• DIRETTIVA 2014/30/UE (EMC) DEL PARLAMENTO EUROPEO E DEL CONSIGLIO del 26 febbraio 2014 concernente l'armonizzazione delle legislazioni degli Stati membri relative alla compatibilità elettromagnetica (rifusione), secondo le seguenti norme armonizzate: / • DIRECTIVE 2014/30/UE (EMC) OF THE EUROPEAN PARLIAMENT AND OF THE COUNCIL, of 26 February 2014 on the harmonisation of the laws of the Member States relating to electromagnetic compatibility (recast), according to the following standards: EN 61000-6-2:2005, EN 61000-6-3:2007+A1:2011

Inoltre il prodotto risulta essere conforme alla seguente direttiva secondo i requisiti previsti per le "quasi macchine": / In addition, the product conforms to the following directive pursuant to the provisions applicable to "partly completed machinery":
 Direttiva 2006/42/CE DEL PARLAMENTO EUROPEO E DEL CONSIGLIO del 17 maggio 2006 relativa alle macchine e che modifica la direttiva 95/16/CE (rifusione) / Directive 2006/42/EC OF THE EUROPEAN PARLIAMENT AND OF THE COUNCIL of May 17 2006 on machinery, amending Directive 95/16/EC (consolidated version)

- Si dichiara che la documentazione tecnica pertinente è stata compilata in conformità all'allegato VII B della direttiva 2006/42/CE e che sono stati rispettati i seguenti requisiti essenziali: / - It is hereby declared that the relevant technical documentation has been compiled in accordance with Annex VII Part B of Directive 2006/42/EC and that the following essential requirements have been applied and fulfilled: 1.1.1-1.1.2-1.1.3-1.2-1.2.6-1.5.1-1.5.2-1.5.5-1.5.6-1.5.7-1.5.8-1.5.10-1.5.11.

- Il produttore si impegna a trasmettere alle autorità nazionali, in risposta ad una motivata richiesta, le informazioni pertinenti sulla "quasi macchina", mantenendo impregiudicati i propri diritti di proprietà intellettuale. / - The manufacturer undertakes to transmit, in response to a reasoned request by the national authorities, relevant information on the "partly completed machinery". This shall be without prejudice to the intellectual property rights of the manufacturer of the partly completed machinery.

- Qualora la "quasi macchina" sia messa in servizio in un paese europeo con lingua ufficiale diversa da quella usata nella presente dichiarazione, l'importatore ha l'obbligo di associare alla presente dichiarazione la relativa traduzione. / - Should the "partly completed machinery" be put into service in a European country with an official language different to the one used in this declaration, a translation into that language must be provided by the person bringing the machinery into the language area in question.

- Si avverte che la "quasi macchina" non dovrà essere messa in servizio finché la macchina finale in cui sarà incorporata non sarà a sua volta dichiarata conforme, se del caso, alle disposizioni della direttiva 2006/42/CE. / - The "partly completed machinery" may not be put into service until the final machinery into which it is to be incorporated has been declared in conformity with the provisions of Directive 2006/42/EC, where appropriate.

Inoltre il prodotto risulta conforme alle seguenti norme: / The product also complies with the following standards: EN 60335-1:2012+A11:2014, EN 62233:2008, EN 60335-2-103:2015.

Il prodotto risulta conforme, limitatamente alle parti applicabili, alle seguenti norme: / All parts of the product subject to the following standards comply with them: EN 60335-1:2012+A11:2014, EN 62233:2008, EN 60335-2-103:2015.

Oderzo, 2 Dicembre 2017 / Oderzo, 2nd December 2017.

Ing. Roberto Griffa
 (Amministratore Delegato / Chief Executive Officer)

- IT - Impianto tipico • EN - Typical installation • FR - Installation type • ES - Instalación típica • DE - Typische Anlage • PL - Typowy system • NL - Gebruikelijke installatie • RU - Типичная установка

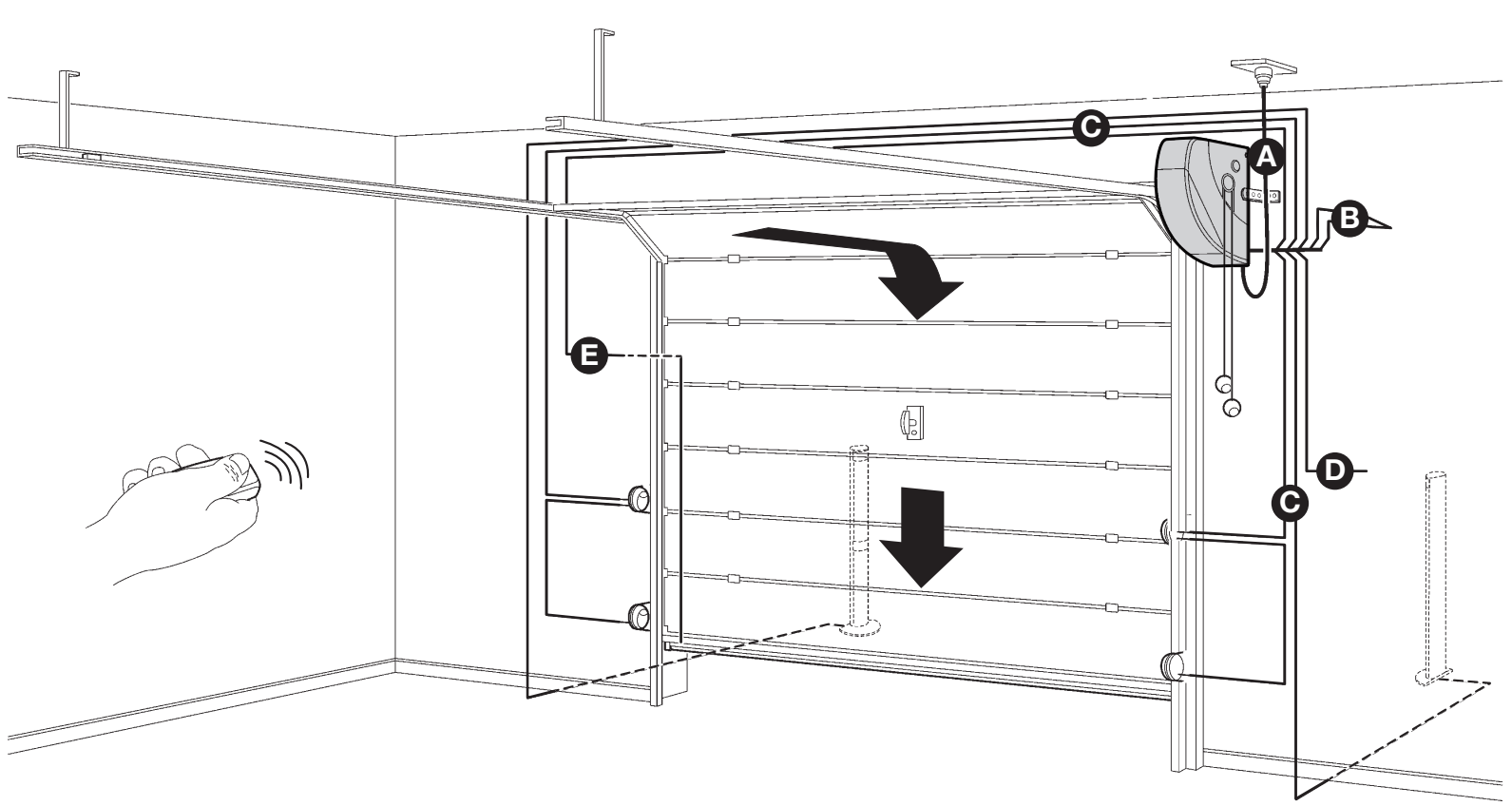

- IT - Cavi da utilizzare • EN - Cables to use • FR - Câbles à utiliser • ES - Cables a utilizar • DE - Zu verwendende Kabel • PL - Kable, jakich należy użyć • NL - Verplichte kabels • RU - Используемые кабели

A	N°1 cable: 3 x 1,5 mm ² (included)	30 m max *
B	N°1 cable: 2 x 1 mm ²	20 m max
C	N°1 cable RG58	20 m max (⌀ < 5 m)
D	N°1 cable: 2 x 0,5 mm ²	30 m max
E	N°1 cables: 4 x 0,5 mm ²	50 m max
F	N°1 cable: 2 x 0,5 mm ²	20 m max

* Cable > 30 m = N°1 cable: 3 x 2,5 mm² + ⊕

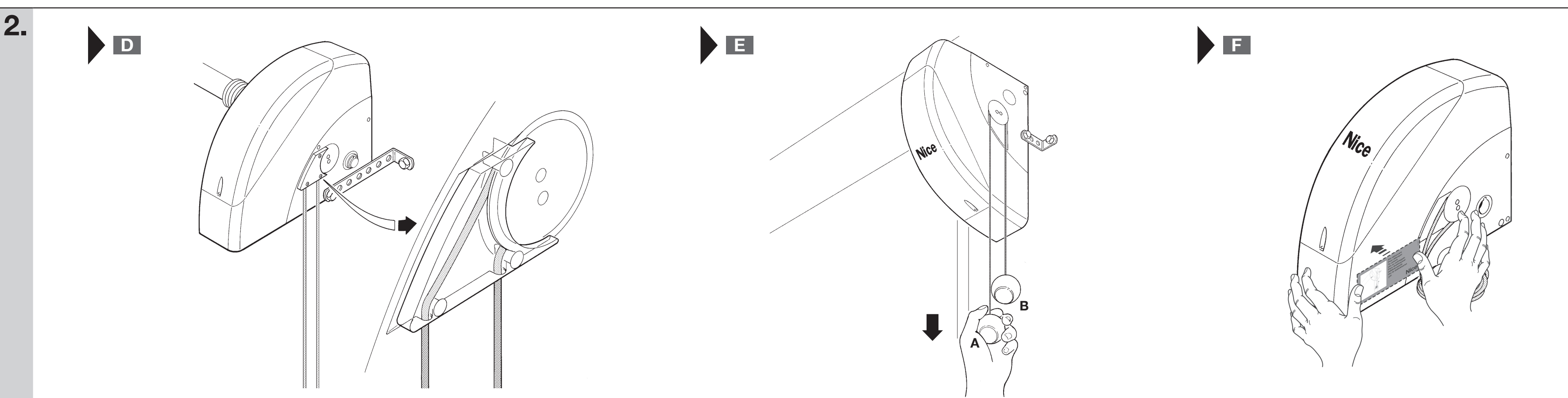
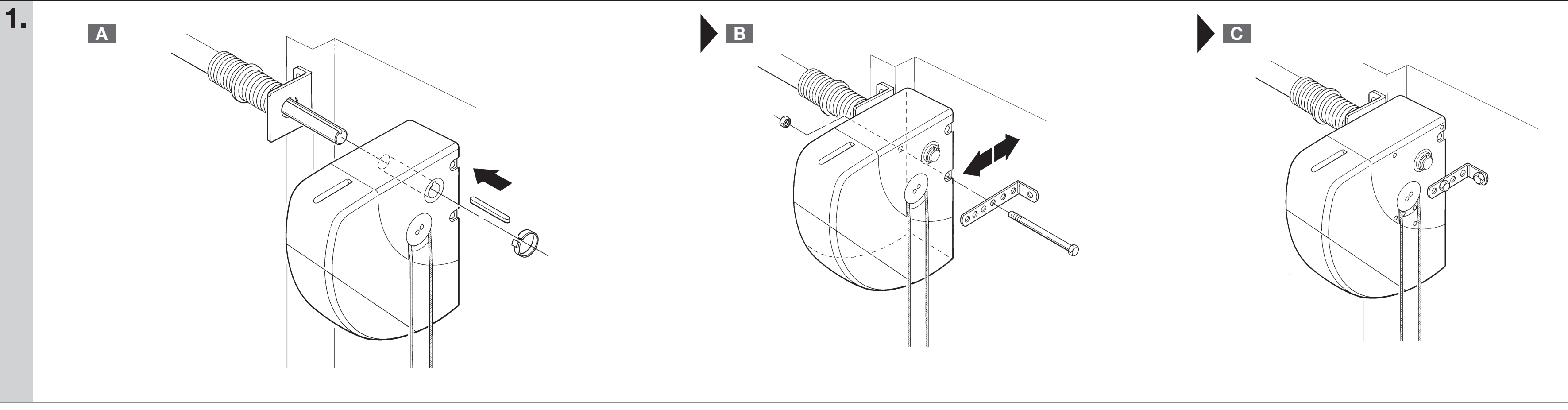
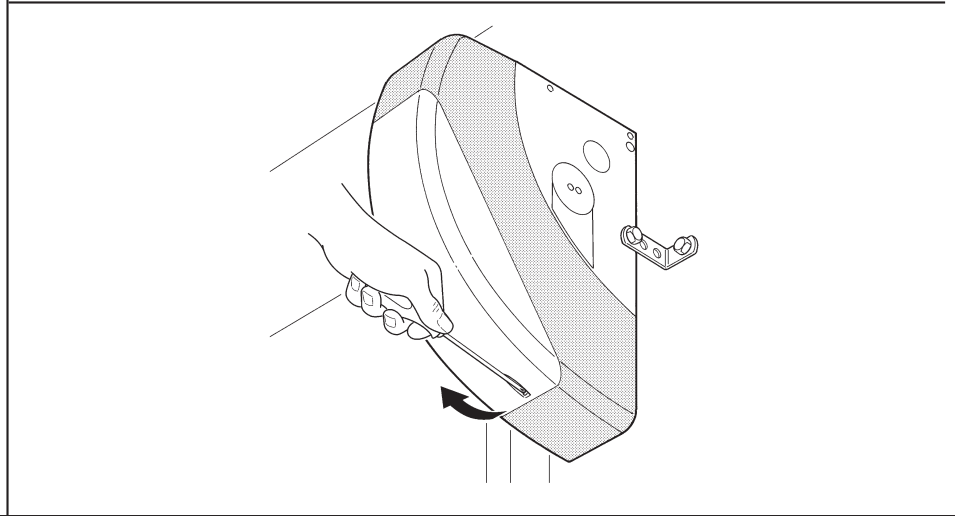
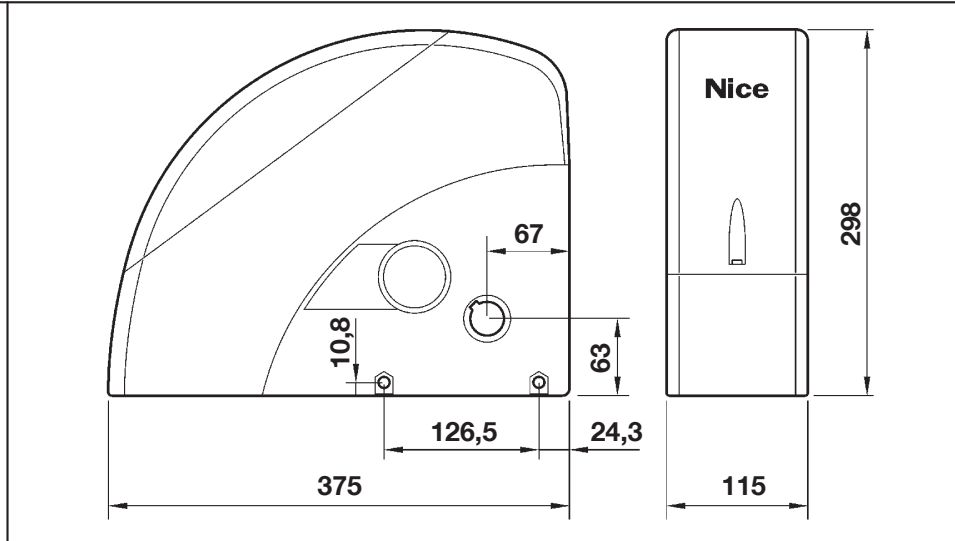

IT Questo manuale è una sintesi delle fasi d'installazione e della messa in funzione con i valori di default: il manuale istruzioni completo (installazione, collegamenti, programmazioni parametri, diagnostica, ecc.) è scaricabile dal sito www.niceforyou.com

EN This manual is a summary of the installation and commissioning instructions, using the default values: the complete user manual (installation, connections, programming, diagnostics, etc.) is available for download from www.niceforyou.com

FR Ce manuel est un résumé des phases d'installation et de mise en service avec les valeurs par défaut : le mode d'emploi complet (installation, raccordements, programmation des paramètres, diagnostic, etc.) peut être téléchargé sur le site Internet www.niceforyou.com

ES Este manual es una síntesis de las fases de instalación y de la puesta en funcionamiento con los valores predeterminados: el manual de instrucciones completo (instalación, conexiones, programación de parámetros, diagnóstico, etc.) se puede descargar del sitio www.niceforyou.com

DE Diese Anleitung gibt einen Überblick über die Einrichtungs- und Inbetriebnahmephase mit den Standardeinstellungen: Die vollständige Anleitung (zu Einrichtung, Anschlüssen, Programmierung der Parameter, Diagnose, usw.) kann auf der Webseite www.niceforyou.com heruntergeladen werden

PL Niniejsza instrukcja jest streszczeniem etapów instalacji i uruchomienia z zastosowaniem wartości domyślnych: pełną instrukcję obsługi (instalacja, podłączenia, programowanie parametrów, diagnostyka, itd.) można pobrać ze strony internetowej www.niceforyou.com

NL Deze handleiding is een samenvatting van de stadia van installatie en inbedrijfstelling met de standaard waarden: de complete handleiding (installatie, bedrading, het programmeren van parameters, diagnostiek etc.) kan worden gedownload van de website www.niceforyou.com

RU Данное руководство являет собой синтез фаз монтажа и пуска в работу согласно стандартно заданным значениям: полное руководство с инструкциями (монтаж, подключения, программирование параметров, диагностика и пр.) может быть загружена с веб-сайта www.niceforyou.com

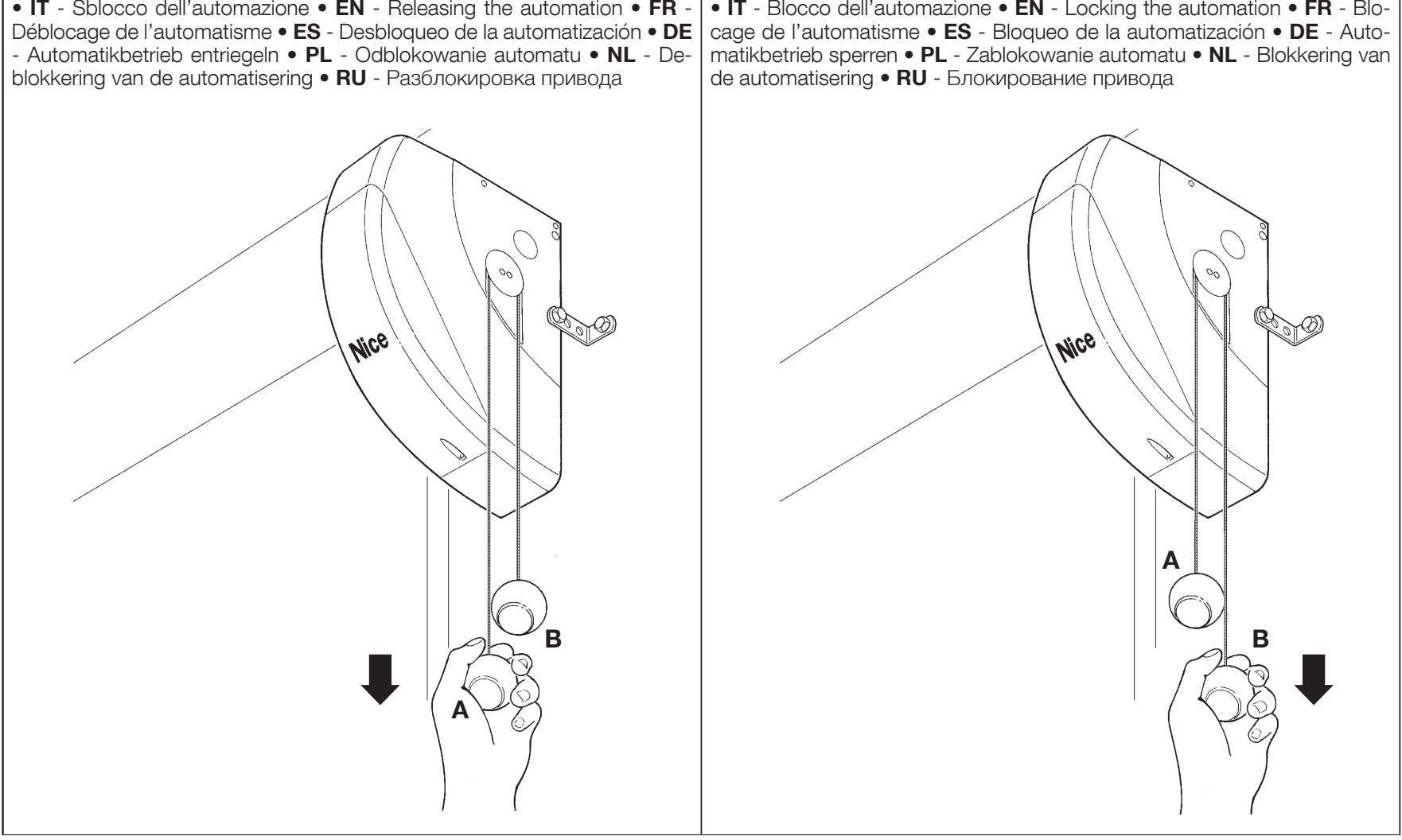

Complete manual: www.niceforyou.com

SERIAL NUMBER: DATE:

• **IT** - Da consegnare all'utilizzatore • **EN** - To be given to the user • **FR** - À remettre à l'utilisateur • **ES** - Para entregar al usuario • **DE** - Dem Endnutzer zu übergeben • **PL** - Do przekazania użytkownikowi • **NL** - Te overhandigen aan de gebruiker • **RU** - Передается конечному пользователю

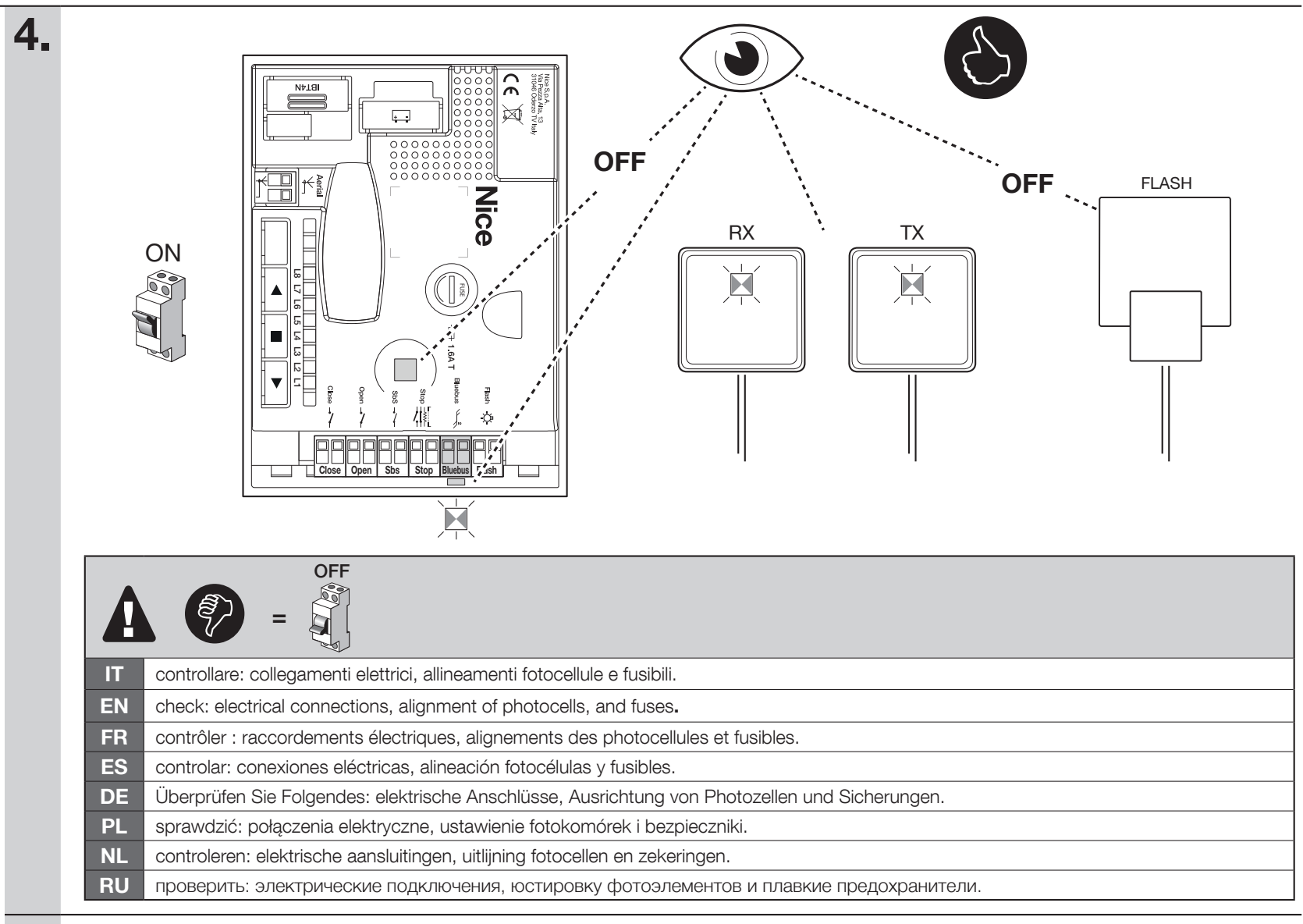
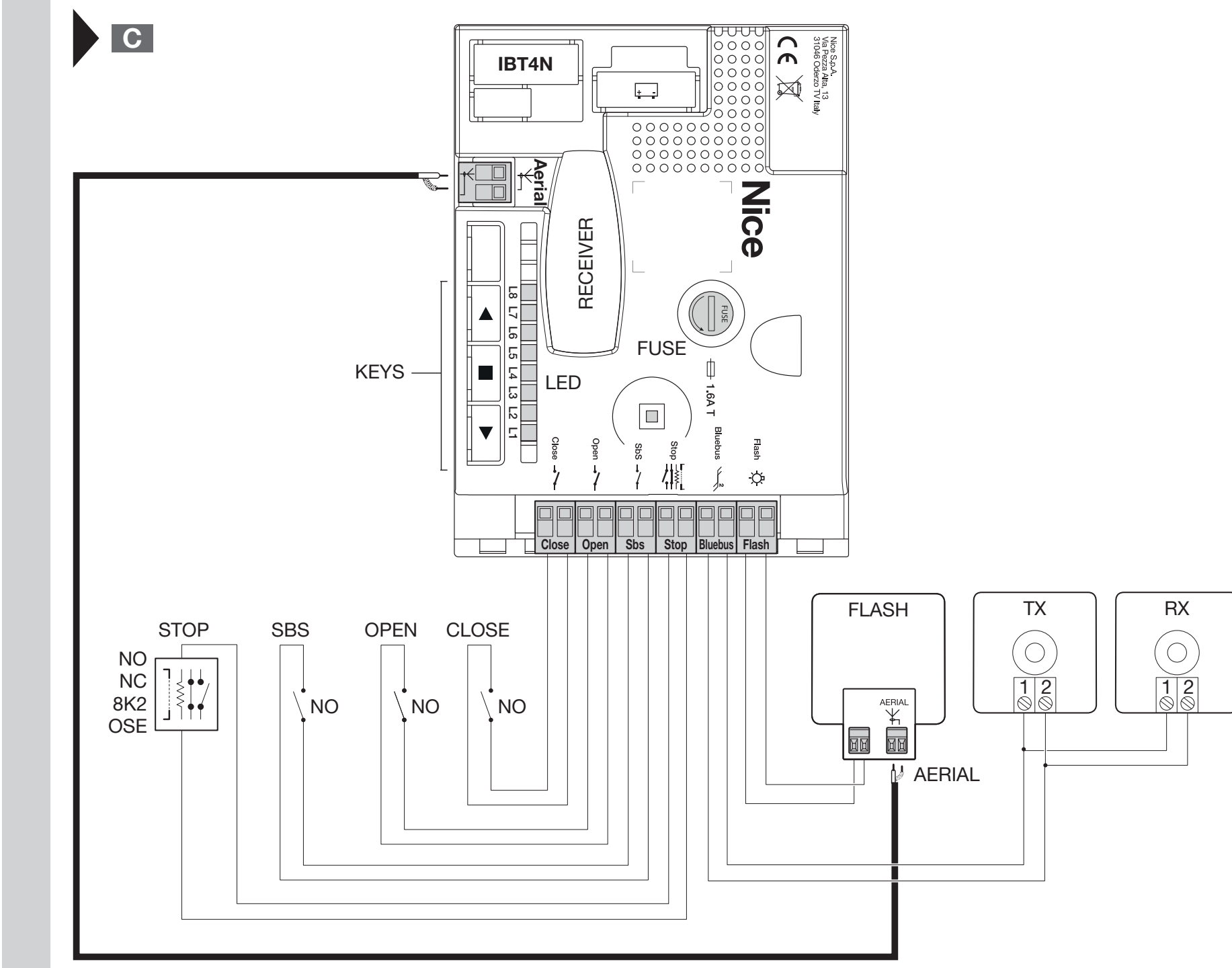
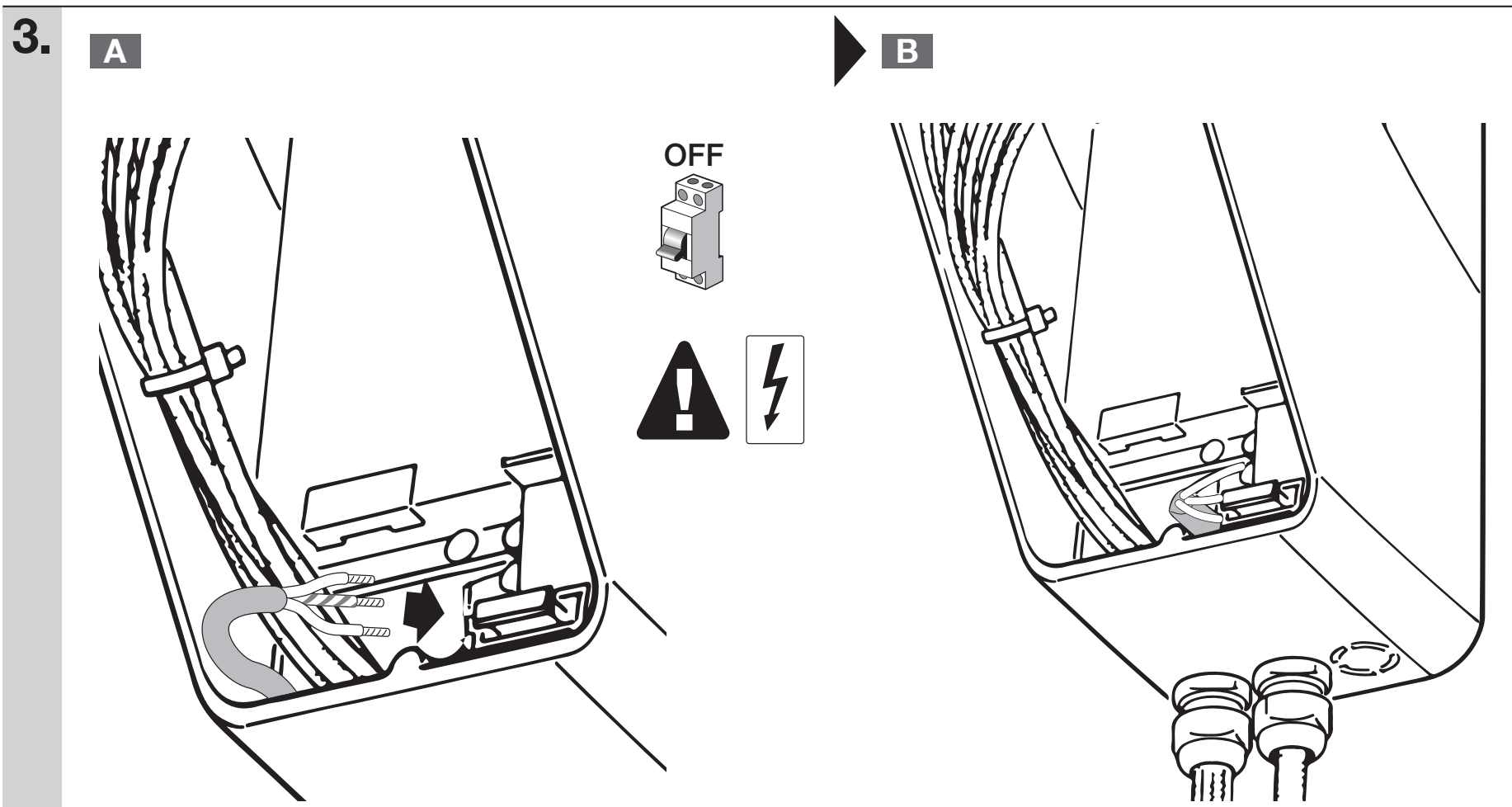

5. • IT - LEGENDA • EN - KEY • FR - LÉGENDE • ES - LEYENDA • DE - LEGENDE • PL - LEGENDA • NL - LEGENDA • RU - УСЛОВНЫЕ ОБОЗНАЧЕНИЯ

	• IT - dare alimentazione elettrica di rete • EN - supply mains power • FR - activer l'alimentation électrique du réseau • ES - conectar la alimentación eléctrica de red • DE - mit dem Stromnetz verbinden • PL - włączyć zasilanie elektryczne • NL - netvoeding inschakelen • RU - включить питание		• IT - led spento • EN - led off • FR - led éteinte • ES - led apagado • DE - led Aus • PL - dioda led zgaszona • NL - Led is uit • RU - СИД выключен
	• IT - togliere alimentazione elettrica di rete • EN - shut off mains power • FR - couper l'alimentation électrique du réseau • ES - desconectar la alimentación eléctrica de red • DE - Die Netzstromversorgung ausschalten • PL - odłączyć zasilanie elektryczne • NL - Netvoeding uitschakelen • RU - отключить сетевое электропитание		• IT - attendere la fine dell'acquisizione dispositivi • EN - wait for the device acquisition phase to end • FR - attendre la fin de l'acquisition des dispositifs • ES - esperar que termine la adquisición de los dispositivos • DE - Ende der Geräteerkennung abwarten • PL - poczekać na zakończenie wczytywania urządzeń • NL - wacht op het einde van het aanleren van de inrichtingen • RU - дождитесь конца опроса устройств
	• IT - osservare • EN - observe • FR - observer • ES - observar • DE - beobachten • PL - obserwuj • NL - wachten • RU - осмотреть		• IT - attendere • EN - wait • FR - attendre • ES - esperar • DE - warten • PL - czekać • NL - wachten • RU - ожидать
	• IT - Corretto • EN - Correct • FR - Correct • ES - Correcto • DE - Richtig • PL - Prawidłowo • NL - Correct • RU - Правильно		• IT - mantenere premuti i tasti • EN - keep the buttons pressed • FR - maintenir enfoncées les touches • ES - mantener pulsadas las teclas • DE - Die Tasten gedrückt halten • PL - przytrzymać wciśnięte przyciski • NL - De toetsen ingedrukt houden • RU - Нажмите одновременно и удерживайте кнопки
	• IT - Non corretto • EN - Incorrect • FR - Incorrect • ES - No correcto • DE - Nicht richtig • PL - Nieprawidłowo • NL - Niet correct • RU - Неправильно		• IT - rilasciare i tasti • EN - release the buttons • FR - relâcher les touches • ES - soltar las teclas • DE - die Tasten loslassen • PL - zwolnić przyciski • NL - laat de toetsen los • RU - отпустить кнопки
	• IT - lampeggio molto veloce led • EN - LED very fast flashing • FR - clignotement très rapide de la led • ES - parpadeo muy rápido del led • DE - Sehr schnelles Blinken der LED • PL - bardzo szybkie miganie diody led • NL - led knippert zeer snel • RU - очень частое мигание индикатора		• IT - premere e rilasciare il tasto • EN - press and release the key • FR - enfoncer et relâcher la touche • ES - pulsar y soltar la tecla • DE - Taste drücken und loslassen • PL - nacisnąć i zwolnić przycisk • NL - de toets indrukken en weer loslaten • RU - нажать и отпустить кнопку
	• IT - lampeggio led • EN - flashing LED • FR - clignotement de la led • ES - led intermitente • DE - Blinken der LED • PL - miganie diody led • NL - led knippert • RU - мигание светодиода		• IT - massima apertura • EN - maximum opening position • FR - position d'ouverture maximum • ES - cota de apertura máxima • DE - maximale Öffnung • PL - maksymalne otwarcie • NL - maximale opening • RU - максимальное открытие
	• IT - led acceso • EN - led on • FR - led allumée • ES - led encendido • DE - Dauerleuchten der LED • PL - dioda led zapalona • NL - led brandt • RU - индикатор горит		• IT - massima chiusura • EN - maximum closing • FR - fermeture maximale • ES - cierre máximo • DE - maximale Schließung • PL - maksymalne zamknięcie • NL - maximale sluiting • RU - максимальное закрытие

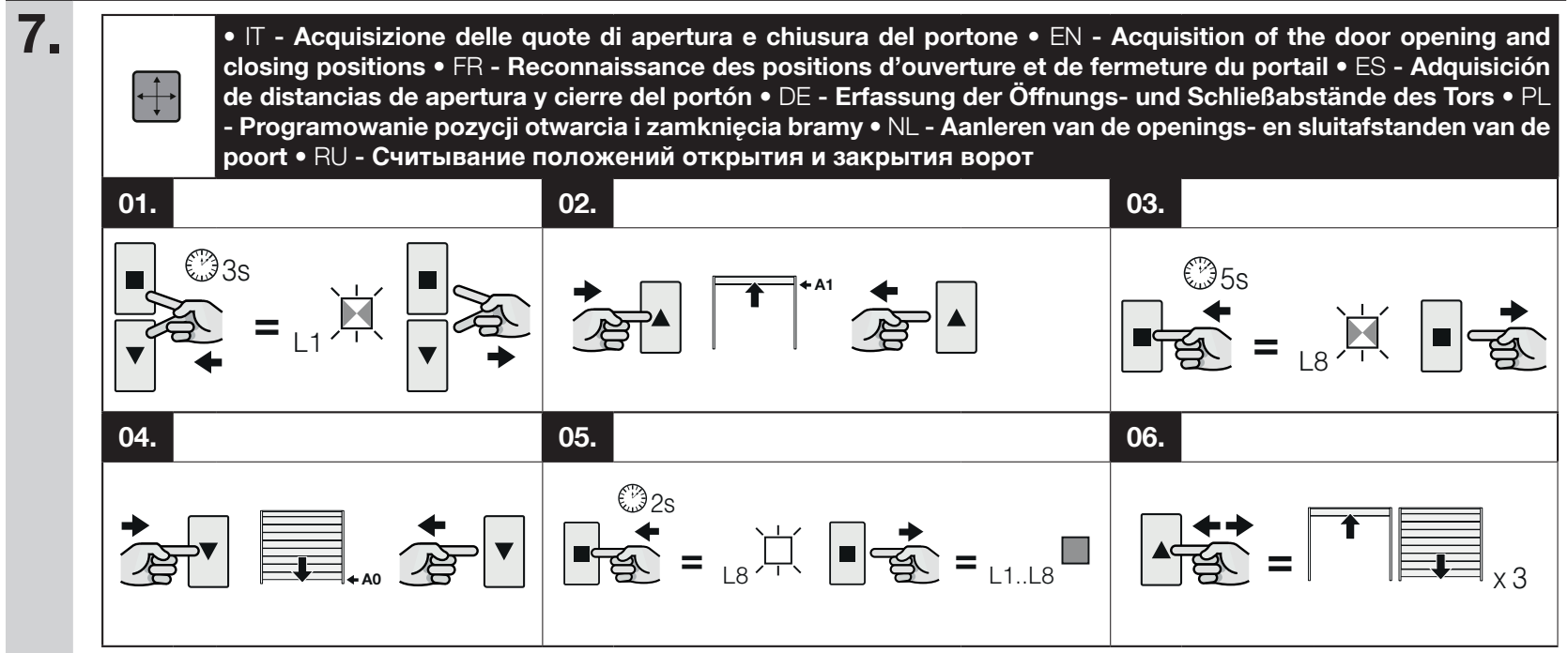
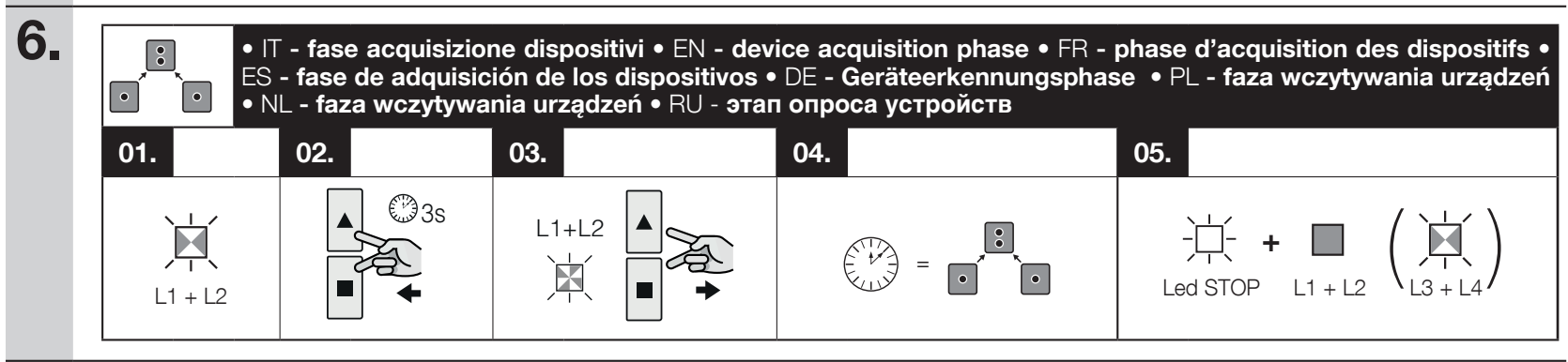

	IT	EN	FR	ES
KEYS	TASTI PROGRAMMAZIONE E COMANDO	PROGRAMMING AND CONTROL KEYS	TOUCHES DE PROGRAMMATION ET COMMANDE	TECLAS DE PROGRAMACIÓN Y MANDO
LED	LED FUNZIONI	FUNCTION LEDS	LED DE FONCTIONS	LED FUNCIONES
RECEIVER	RICEVITORE RADIO	RADIO RECEIVER	RÉCEPTEUR RADIO	RADIORRECEPTOR
AERIAL	ANTENNA	AERIAL	ANTENNE	ANTENA
FUSE	FUSIBILE	FUSE	FUSIBLE	FUSIBLE
TX - RX	FOTOCÉLULLE	PHOTOCELLS	PHOTOCÉLULES	FOTOCÉLULAS
FLASH	LAMPEGGIANTE	FLASHING LIGHT	CLIGNOTANT	INTERMITENTE
STOP	STOP	STOP	STOP	STOP
NO-NC-8K2-OSE	BORDO SENSIBILE	SENSITIVE EDGE	BARRE PALPEUSE	BANDA SENSIBLE
SBS	PASSO-PASSO	STEP BY STEP	PAS À PAS	PASO A PASO
OPEN	APRE	OPEN	OUVERTURE	ABRIR
CLOSE	CHIUDE	CLOSE	FERMETURE	CERRAR
▲	Tasto "APRE"	"OPEN" Button	Touche "OUVERTURE"	Botón "ABRE"
▼	Tasto "CHIUDE"	"CLOSE" Button	Touche "FERMETURE"	Botón "CIERRA"
■	Tasto "STOP/SET"	"STOP/SET" Button	Touche "STOP/SET"	Botón "STOP/SET"

	DE	PL	NL	RU
KEYS	PROGRAMMIER- UND BEFEHLSTASTEN	PRZYCISKI PROGRAMUJĄCE I STEROWNICZE	PROGRAMMERINGS- EN BEDIENINGSTOETSSEN	КЛАВИШИ ПРОГРАММИРОВАНИЯ И УПРАВЛЕНИЯ
LED	FUNKTIONSANZEIGE-LED	DIODY LED FUNKCJI	FUNCTIELEDS	СВЕТОДИОДЫ ФУНКЦИЙ
RECEIVER	FUNKKEMPFÄNGER	ODBIORNIAK RADIOWY	SIGNAALONTVANGER	РАДИОПРИЕМНИК
AERIAL	ANTENNE	ANTENA	ANTENNE	АНТЕННА
FUSE	SICHERUNG	BEZPIECZNIK	ZEKERING	ПРЕДОХРАНИТЕЛЬ
TX - RX	FOTOCÉLLEN	FOTOKOMÓRKI	FOTOCÉLLEN	ФОТОЭЛЕМЕНТЫ
FLASH	BLINKLEUCHTE	LAMPA OSTRZEGAWCZA	KNIPPERLICHT	ПРИБЛЕСКОВАЯ ЛАМПА
STOP	STOP	STOP	STOP	STOP
NO-NC-8K2-OSE	SCHALLLEISTE	LISTAWA KRAWĘDZIOWA	CONTACTLIJST	ЧУВСТВИТЕЛЬНАЯ КРОМКА
SBS	SCHRITTBETRIEB	KROK PO KROKU	STAP-VOOR-STAP	ПОШАГОВО
OPEN	ÖFFNET	OTWARCIE	OPEN	ОТКРЫТЬ
CLOSE	SCHLIESST	ZAMKNIĘCIE	SLUIT	ЗАКРЫТЬ
▲	Taste "ÖFFNET"	Przycisk "OTWIERA"	Toets "OPENEN"	Кнопка "ОТКРЫТЬ"
▼	Taste "SCHLIESST"	Przycisk "ZAMYKA"	Toets "SLUITEN"	Кнопка "ЗАКРЫТЬ"
■	Taste "STOP/SET"	Przycisk "STOP/SET"	Toets "STOP/SET"	Кнопка "STOP/SET"