



# Loop Installation Manual

# Loop Installation



Weiss-Electronic GmbH  
Niederkircher Straße 16  
54294 Trier  
Germany

<http://www.weiss-electronic.de>

© 2006 All rights reserved

## Contents

<b>1</b>	<b>GENERAL DESCRIPTION</b> .....	<b>4</b>
<b>2</b>	<b>MODE OF OPERATION</b> .....	<b>5</b>
<b>3</b>	<b>INDUCTION LOOP</b> .....	<b>7</b>
<b>4</b>	<b>INSTALLATION OF THE LOOP</b> .....	<b>7</b>
<b>5</b>	<b>CASTING COMPOUND</b> .....	<b>9</b>
5.1	COLD CASTING COMPOUND .....	9
5.2	HOT CASTING COMPOUND .....	9
<b>6</b>	<b>FEED CABLE OF THE LOOP</b> .....	<b>9</b>
<b>7</b>	<b>GEOMETRY OF THE LOOP</b> .....	<b>10</b>
<b>8</b>	<b>SPECIAL AREAS OF USE</b> .....	<b>11</b>
8.1	DETECTION OF TWO-WHEELED VEHICLES.....	11
8.2	TRAMWAYS AND TRAINS.....	12
8.3	AUTOMATIC TRANSPORTATION SYSTEMS.....	12
8.4	BUS DETECTION .....	13
<b>9</b>	<b>SPECIAL CASES</b> .....	<b>14</b>
9.1	HEAVY IRON REINFORCEMENT.....	14
9.2	ELECTRIC HEATING BLANKETS .....	15
9.3	LOOP LAYING UNDER INTERLOCKING STONE PAVING .....	15
<b>10</b>	<b>DIRECTIONAL LOGIC</b> .....	<b>16</b>
10.1	FUNCTION.....	17
10.2	LAYING OF THE LOOP WITH DIRECTIONAL LOGIC .....	18
<b>11</b>	<b>NOTES ON OVERVOLTAGE PROTECTION</b> .....	<b>18</b>
<b>12</b>	<b>NOTES ON THE LOOP WIRE</b> .....	<b>19</b>

## Symbols

In several places throughout this manual you will find the following symbols stating important safety instructions:



### ATTENTION!

This symbol indicates dangers which might cause damage to people or property



### NOTE

This symbol indicates information for installation and function of the device

## 1 General Description

Inductive impulse transmitters are the most frequently used devices for the detection of vehicles of all sorts. The induction loop as sensor of these inexpensive devices is characterized by its robust and weather-independent structure.

These advices for the laying of loops relate to the following areas of use:

Gates: Automatic opening and closing of gates, shutters, barriers, etc.

Parking lots: Monitoring of single parking spaces  
Control of barriers  
Counting in parking garages

Rail-bound vehicles: Opening and closing of hall gates  
General detection for other control purposes

The following features apply for the Weiss-Electronic induction impulse transmitters:

- Microprocessor controlled
- Static hold time
- High sensitivity of max. 0.02%  $\Delta f/f_0$
- Multi-channel version, max. 4 channels
- Wide operation range 10  $\mu\text{H}$  - 2000  $\mu\text{H}$
- Temperature compensation
- Automatic alignment

These characteristics are typical values, the characteristics indicated in the data sheet of each device must be observed.

## 2 Mode of Operation

The induction loop is the inductive part of an L-C oscillator. The loop inductivity and the capacity of the internal capacitor determine the resonance frequency  $f_o$  of this resonating circuit. With some devices, the capacity of the capacitor and so the resonance frequency can be modified by switches resp. jumpers.

Other detectors can be set via software to different measuring frequencies.

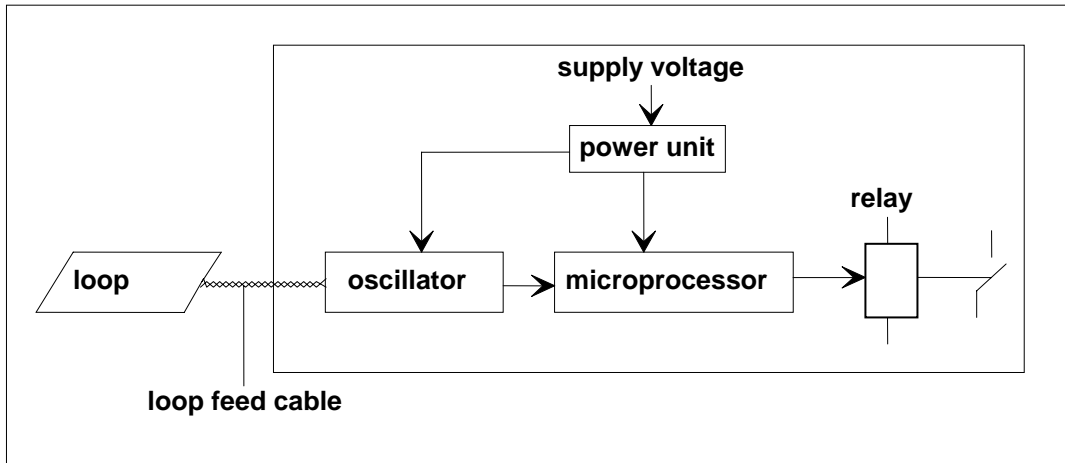

For the induction loop applies the following rule:  
*The lower the inductivity the higher the frequency  $f_o$ .*

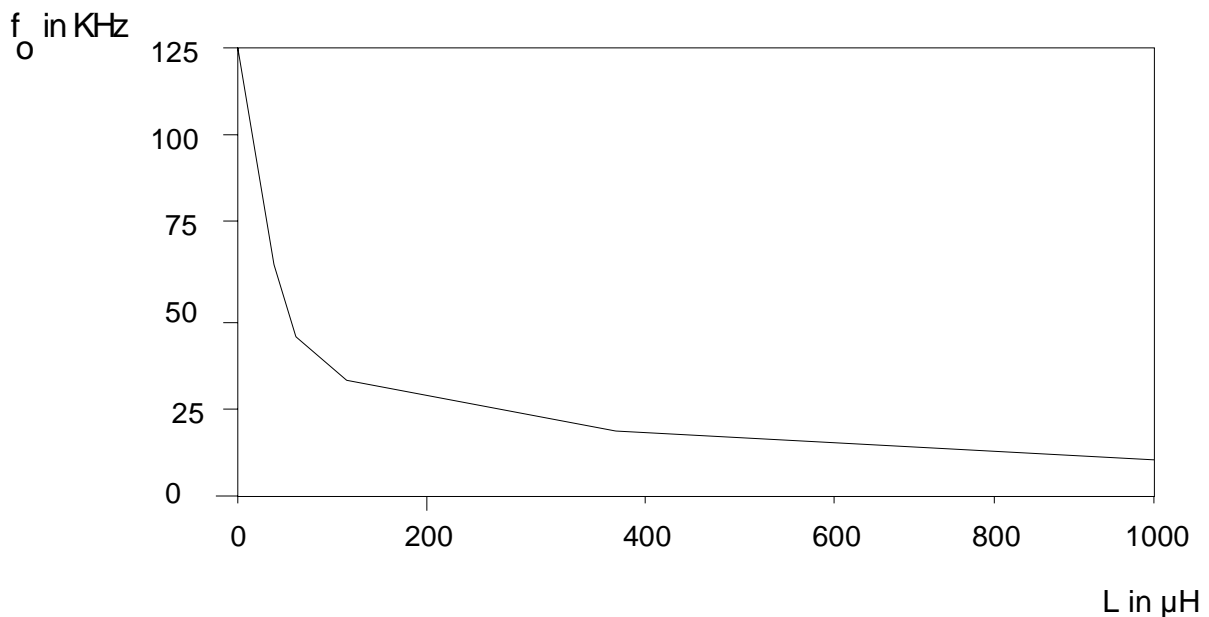

Example of the dependence of  $f_o$  on L

# Loop Installation

In order to explain the function we first look at the un-attenuated loop. A magnetic alternating field is formed around the loop flow through by the electric current.

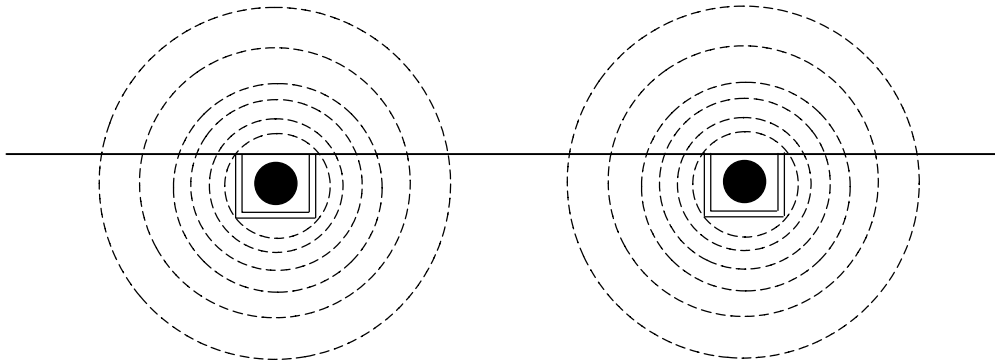

At the same time the magnetic field lines close on the shortest way.

Now a vehicle drives onto the induction loop.

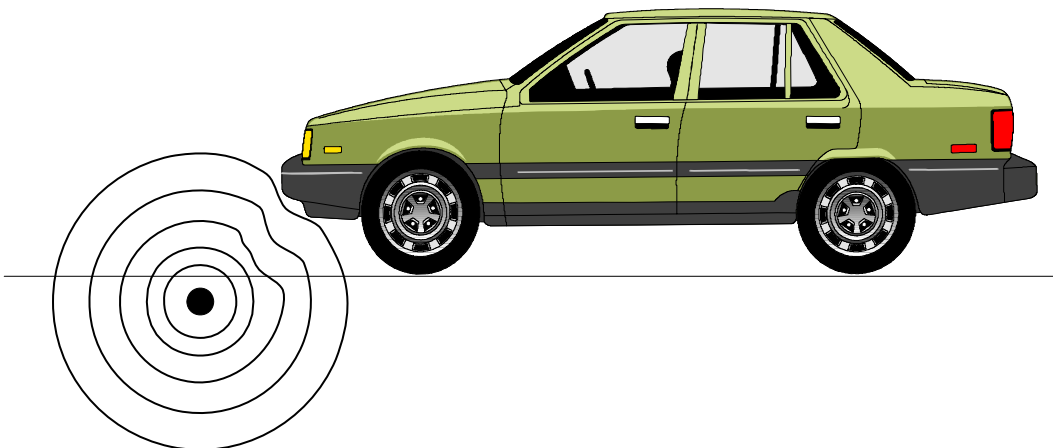

In the vehicle's chassis, currents are induced by the alternating field of the loop. These currents form a magnetic field themselves and have a counter-effect on the original field. The field lines of the induction loops are diverted by this magnetic field and do not close on the shortest way any more.

As the inductivity gets smaller with a growing field line length, the inductivity of the loop decreases. The frequency increases. The microprocessor detects this frequency change.

With a frequency change higher than the switching threshold, the microprocessor switches on the relay contact of the detector. The switching threshold is set via the sensitivity. If a high sensitivity is set there will be a low switching threshold. If a low sensitivity is set there will be a high switching threshold. The sensitivity should not be set higher than necessary for the individual application.

Very slow changes of the loop frequency (e.g. caused by temperature changes) do not lead to a switching.

## 3 Induction Loop

For most applications, the induction loop is laid in a square or rectangular form. According to the loop's circumference, a different number of turns must be laid into the loop slot.

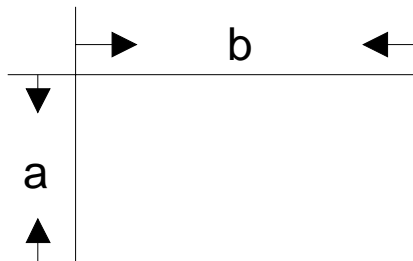

The table shows the requested number of turns at different circumference ranges (for a side ratio of  $b:a = 3:1$ ).

Circumference	Number of turns
4 - 5 m	5
5 - 6 m	4
6 - 15 m	3
15 - 25 m	2

For more information please read the specifications for the usage according to regulations in the according user manual of the detector.

## 4 Installation of the Loop

In order to lay the loop into the ground covering, at first a slot must be cut into the concrete or asphalt with a diamond disk. This slot should be approx. (40 – 70) mm deep and (5 – 8) mm wide.

The next step is the cleaning of the slot. Dampness must be avoided. After that, the loop wire can be laid in.

As loop wire, a standard flexible and isolated copper line HO7V-K1.5 (NYAF1.5 mm<sup>2</sup>) can be used.

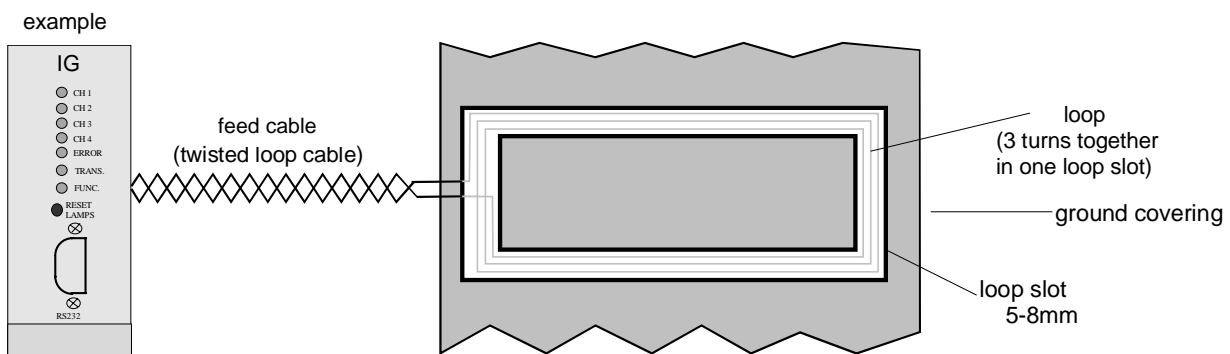

# Loop Installation



If the loop is casted with hot bitumen, a temperature-resistant loop wire must be used.

In the area of doors, gates and barriers, a diagonal joint are to be cut at the edges with an angle of 45°, through which the loop wire is led. With this you avoid putting too much strain on the edges of the loop cable.

In the area of motorways, the rounding off of the sharp joint edges by drilling is advisable. There is the danger of breaking edges because of the strain caused by passing vehicles. It is therefore better to do a drilling for this area.

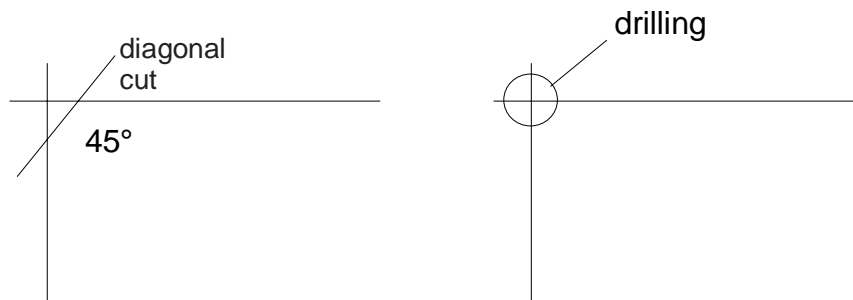

Attention should be paid to the following points when laying induction loops:

- The ground covering must be continuously solid and without cracks.
- A diagonal joint must be cut at the joint edges or the edge must be drilled.
- When laying the loop wires into the slot, one should pay special attention to the edges.
- The loop wire must not show any insulation damages.
- The loop wire may not stick out of any part of the slot, since the isolation will otherwise be destroyed or the wire will tear. When putting in the loop wire, it is better to protect it from washing up with wooden wedge during the casting.
- The loop wires may not move after the casting.  
The loop slot must be clean and dry before casting.
- With an L-Meter or a Weiss Electronic diagnostic device, the loop inductivity should be measured.
- The insulation resistance is to be measured with an insulation testing device against earth (values > 500 MΩ at 500 V measurement voltage and recently installed loops)

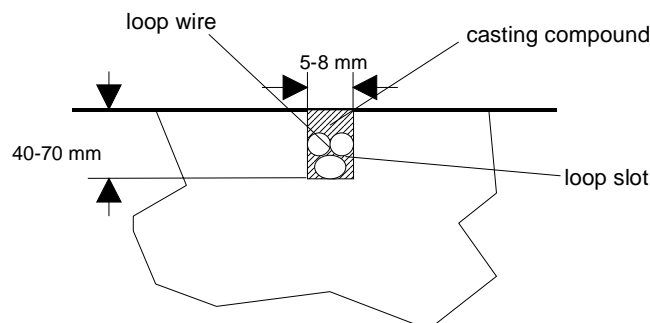



## 5 Casting Compound

### 5.1 Cold casting compound

In many cases, a two-component casting compound on a synthetic resin basis is used. This casting compound must remain in permanent flexibility after the casting so that the casting compound does not get crumbly, even in a cold environment.



The loop cut must be casted properly. Use only as much of the casting compound as needed to fill the loop slot.

### 5.2 Hot casting compound

When working with hot casting compound, the same points should be observed as with cold casting compound.



With hot casting compound, use only copper alloy wire or wire with heat-resistant insulation!

Should you use cable without heat-resistant insulation, glass sand must be filled in the slot after the laying of the loop wire (approx. 1 cm), in order to protect it from the heat of the casting compound.

## 6 Feed cable of the Loop

The loop feed cable is often the reason for occurring detector failures.

Attention must be paid to the following points when operating and laying the loops:

- The two loop feed cables must be twisted with approx. 20 - 50 turns per meter (depending on type of cable).
- The loop feed should not be laid parallel to other electric circuits. A distance of approx. 10 cm to all nearby lines must be kept.
- The loop feed must be twisted and installed carefully in the cabinet too.
- Loop feeds of different detectors also must also be laid in distance to each other.
- Do not lay the feed cable through the loop slot of a neighbouring loop.

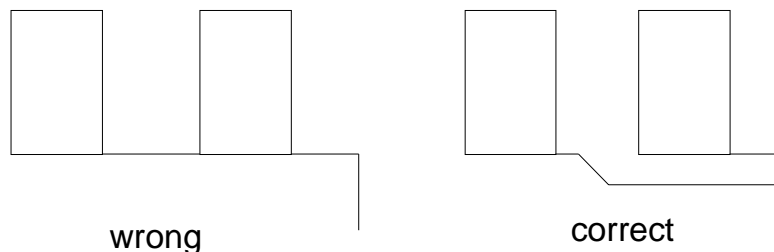

- Protect the feed cable against mechanical damage.
- The ohmic resistance (feed cable plus loop) mustn't become too high in relation to the loop inductivity. Corresponding information can be found in the data sheets of the detectors. In general: The higher the ohmic resistance, the higher the loop inductivity must be chosen.

## 7 Geometry of the Loop

With certain applications, the inductivity also depends on the geometry of the loop. The loop geometry must be adjusted according to its application. Therefore, a loop with a length of 5 m and a width of 0.2 m is very unfavourable. The width of the loop must be adjusted to the vehicle width. The highest sensitivity will be achieved if the vehicle is a little bit wider than the loop.

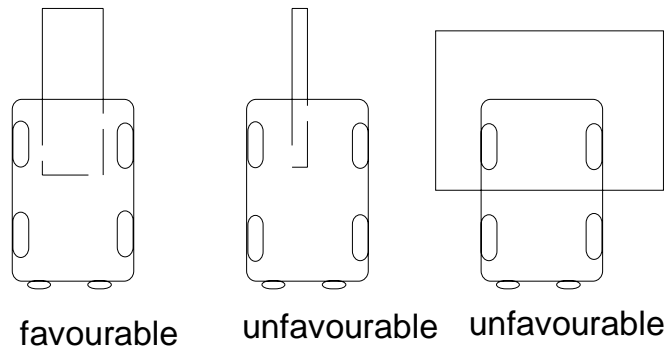

Nearby loops of different detectors must be laid with a space of 1 m to 1.5 m (depending on the loop size). Interfering frequencies from loop to loop will be diminished.

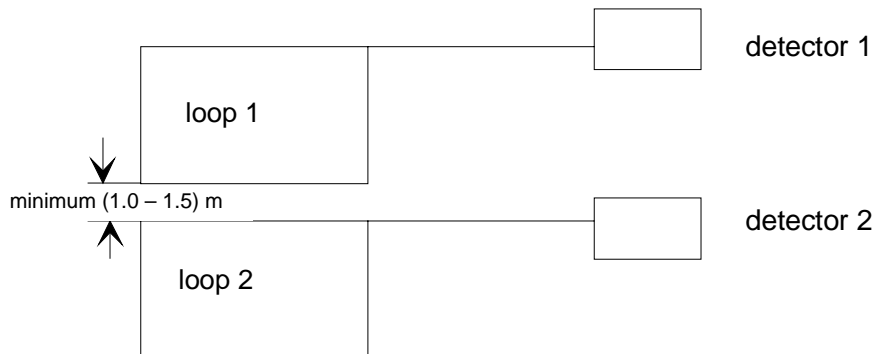

If multichannel detectors are used, the loops of one device can be laid with very little distance or even in an interlocking way.

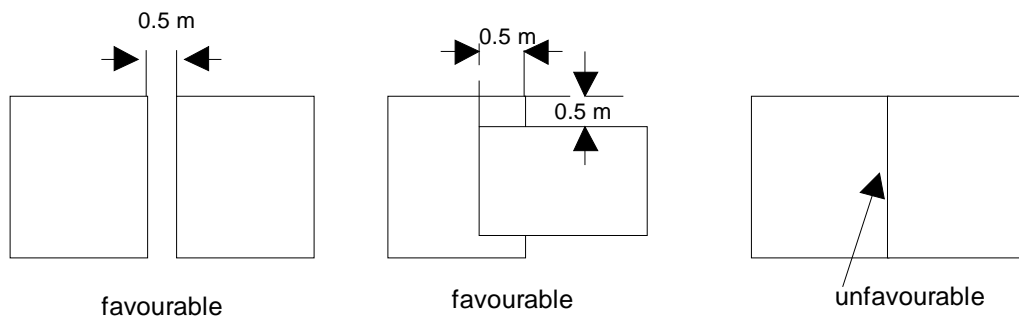

Special forms like T-double-angles, etc. can be realized.

Special forms

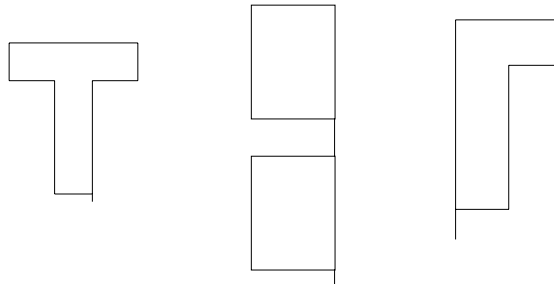

A loop should not be narrow or small, otherwise the detection will decrease. This must be especially taken into account for vehicles with a high ground clearance (e.g. lorries) or small attenuation surface (e.g. bicycles).

As a rule: A vehicle causes a approx. 3-times higher attenuation compared to a lorry.

The loop should have an appropriate length in order to avoid a fade-out of the drawbar-area of lorries with trailer.

## 8 Special Areas of Use

### 8.1 Detection of Two-Wheeled Vehicles

Two-wheeled vehicles cause only minor frequency changes, which is in most applications just above the switching threshold.



Most of the times, the attenuation is not sufficient to signal a sure permanent occupancy. Therefore, the loop should be laid in an angle of  $45^\circ$  to the travel direction, if possible. This will cause an increase of sensitivity. If there is iron reinforcement underneath the loop, in most cases the detection of two-wheeled vehicles is no longer certain. Preliminary tests with the loop diagnosis device (SDG) must be carried out here.

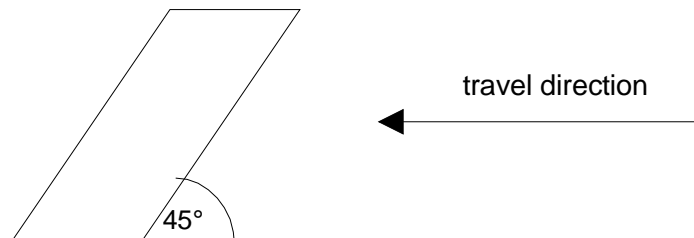

# Loop Installation

## 8.2 Tramways and Trains

To detect rail-bound vehicles, the loop is laid between the tracks.



The distance to the track must be a minimum of 20 cm (pre-attenuation!).

The loop is laid in the shape of an eight so that interference voltages of currents in the tracks can be compensated in the loop circuit.

The loop must be firmly embedded, a change of position through vibration will lead to interferences. Because of the high clearance of these vehicles, there is often only axle detection possible.

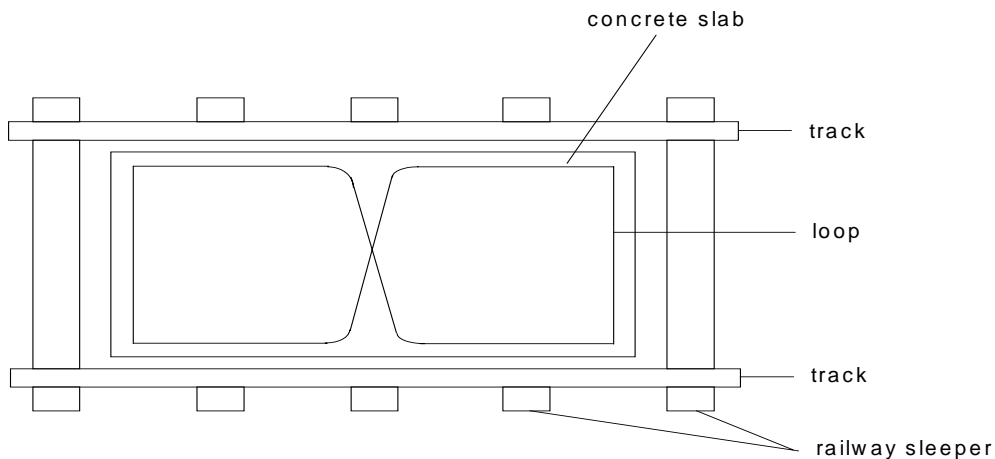

## 8.3 Automatic Transportation Systems

In conducted transportation systems, the vehicles are lead by means of contact wires and are detected at certain sites by induction loops.



The loop must be laid symmetrically to the contact wire (neutralization of the induced interference voltage). Do not lay the loop feed into the slot of the contact wire.

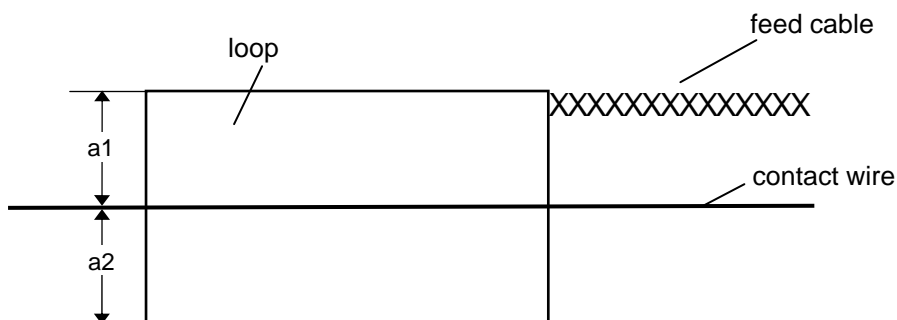

$$a1 = a2$$

## 8.4 Bus Detection

The following Weiss-Electronic detectors are suited for the detection of busses by means of single loops:

- IG745/3
- IG224/4

These detectors use algorithms, which allow low-cost and reliable bus detection in connection with special loop geometry. More information about the bus classification you will find in the according user manuals.

The induction loop for the bus detection must be installed in the middle of the lane and must have the following features:

- Length: 10 m
- Width: 2.5 m
- Number of turns: 2
- Inductivity: approx. 150  $\mu$ H

The detection of busses is due to the higher disturbance the bus causes by completely covering the loop. For a reliable functioning, the loop mustn't be installed in a dusty area (e.g. in close proximity to an intersection), since cars driving closely behind each other can cause a similarly high disturbance on the bus loop.

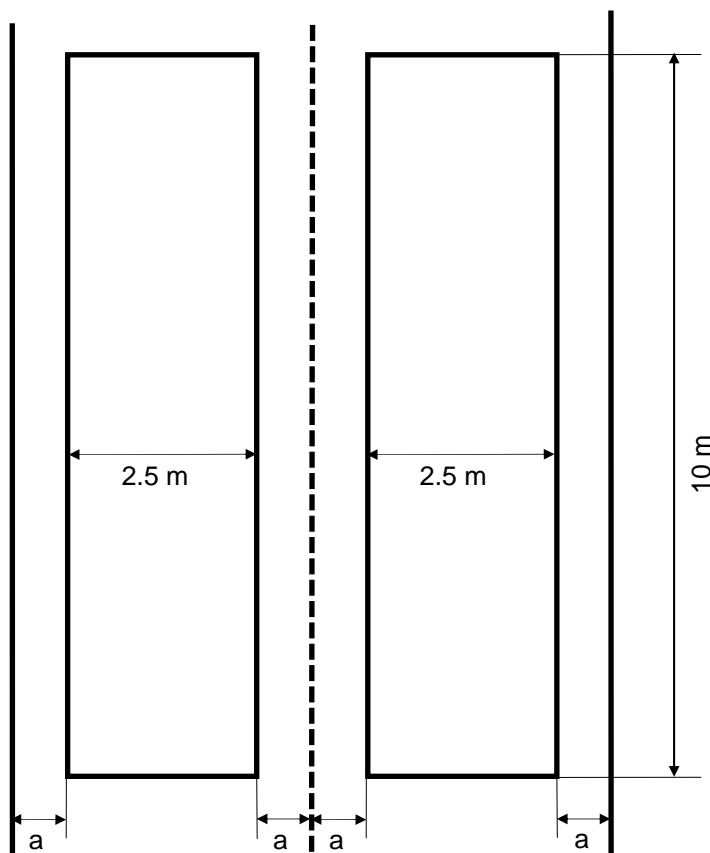

Installation of the bus loop in the middle of the lane

## 9 Special Cases

### 9.1 Heavy Iron Reinforcement

Iron reinforcement in the ground lowers the sensitivity of the induction loop. The smaller the distance of the loop to the iron reinforcement, the lower the sensitivity becomes.

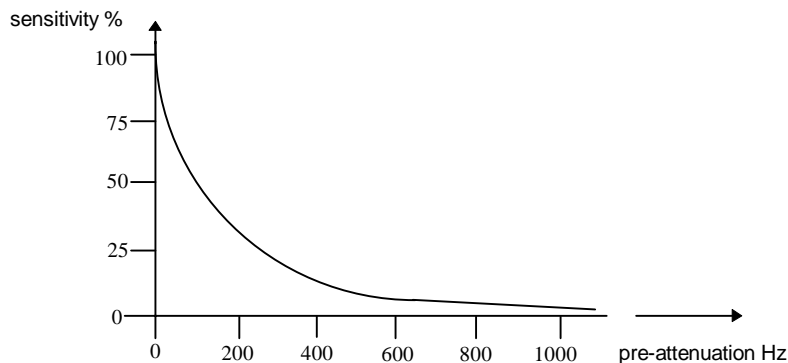

The exemplary curve shows how the switching level decreases with increasing attenuation.

A 100 % switching level corresponds to the un-attenuated loop without iron reinforcement. Especially with lorries, the pre-attenuation must be taken into account because of their high ground clearance.

Here should be proceeded as follows before the final laying of the loops:

#### a) If a loop diagnosis device (SDG2) for the measurement of the pre-attenuation is available:

- Measure the level of pre-attenuation with the measuring device and the reference loop
- Measure an area for the loop installation in which the pre-attenuation is relatively small
- After that, lay a provisional loop of the desired size on the ground and fix it with adhesive tape
- Connect the diagnostic device to the loop. The detector must not be connected
- Measure the alignment frequency of the loop with the loop diagnosis device
- Drive onto the loop with the according vehicle.
- Measure the frequency change level with the diagnosis device. It is a gauge for sensitivity. The Weiss-Electronic detectors switch in the highest level of sensitivity at  $\Delta f/f_0 = 0.02\% - 0.01\%$
- To detect a vehicle reliably, frequency changes in the order of  $\Delta f/f_0 \approx 0.2 - 0.5\%$  are desired. This must be observed especially for induction loops with a safety function

## b) If no diagnosis device is available:

- Lay loop in desired geometry and fix it with adhesive tape
- Connect detector and switch it on
- Attenuate the loop with the respective vehicle and check the hold time
- Move the vehicle off the loop.
- Repeat these steps with different sensitivity levels



The change of position when passing the loop can cause frequency changes

Always observe the following notes:

- Keep the distance between loop and reinforcement as great as possible (at a minimum of approx. 70 cm). The smaller the distance, the lower the sensitivity is
- In the planning state, do not use iron reinforcement or lay it the deeper into the loop area, if possible.
- Tracks, supports, ground grids or steel constructions must be treated like iron reinforcement. Here, a minimum distance of 20 cm should be kept.

## 9.2 Electric Heating Blankets

Often, driveway ramps are equipped with electric heating blankets. Do not lay any loops on these blankets, since the magnetic interferences are too strong.

Already during the planning, enough space should be provided for the induction loop.

The distance between loop and heating blanket should be at a minimum of 1 m on each side.

## 9.3 Loop Laying Under Interlocking Stone Paving

The loops are laid in the sand layer between the layer of broken stones at the bottom and the interlocking paving stones on the top.

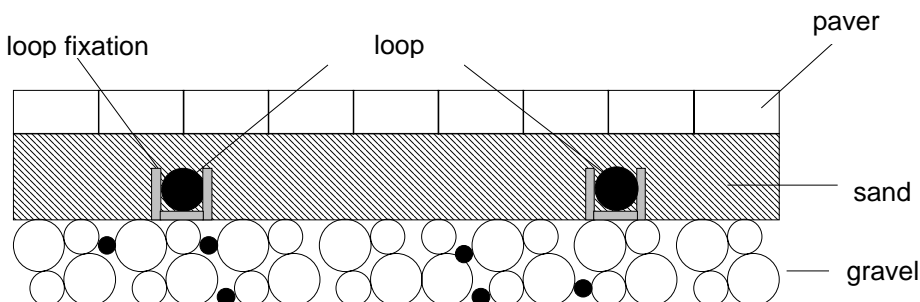

# Loop Installation



Most advantageous is the use of prefabricated cable loops of Weiss-Electronic.

<b>KAS I</b>	6 m circumference, 15 m feed cable
<b>KAS II</b>	12 m circumference, 15 m feed cable
<b>KAS III</b>	21 m circumference, 15 m feed cable

- Lay the cable duct (e.g. 1.5 cm x 1.5 cm, like the ones used for electrical installation) halfway into the sand layer.
- Put in loop and fix.
- Fill with permanently elastic sealant (e.g. loop sealant).

These frame loops are also offered completely by Weiss-Electronic

<b>RS</b>	1.80 m * 0.80 m, 10 m feed cable
<b>RS-S</b>	customized type

Afterwards:

- Fill in sand layer and compress it
- Put in stones and vibrate
- Measure insulation resistance
- Measure inductivity
- Check function

## 10 Directional Logic

The microprocessor-controlled induction pulse generator in 2- and 4-channel version can be delivered with directional logic.

Hereby, 2 channels (channels 1 and 2, as well as channels 3 and 4) each form a directional logic.

### Application for Directional Logic

- direction-dependent control of barriers, garage driveways and gate systems
- entry and exit countings in parking garages
- detection of wrong-way drivers



## 10.1 Function

The directional logic is explained on the following example:

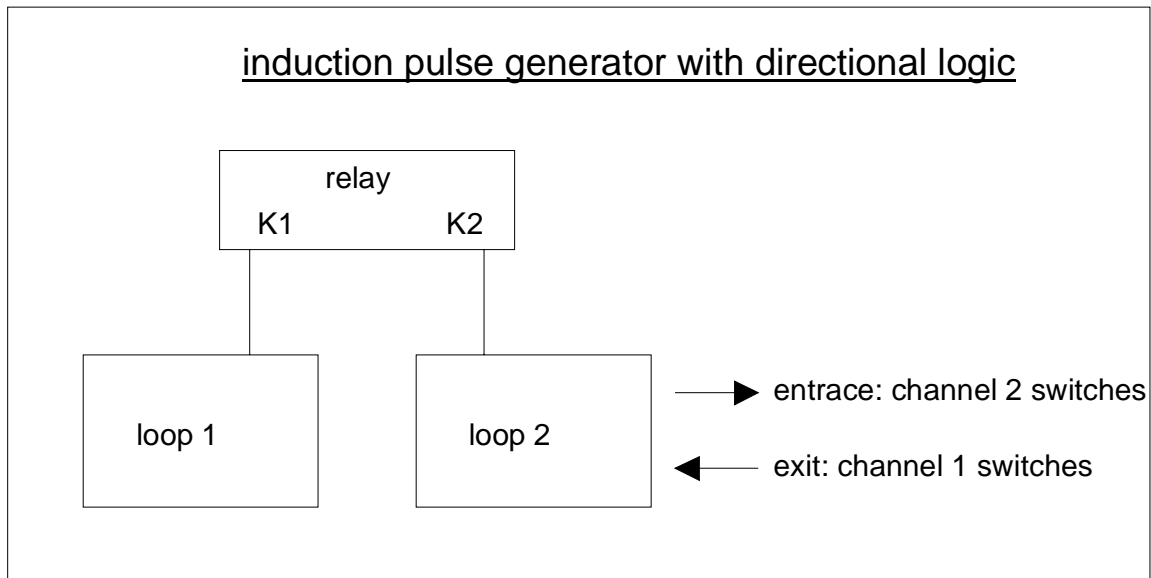

After the attenuation of loop 1, this is recorded in the detector, but no output is switched yet. Only when loop 2 is also simultaneously attenuated, the relay of the second channel switches on and stays switched until loop 2 is released again.

For the other direction (in this case exit), the switching process happens in reverse order. Here, relay channel 1 switches on when both loops are attenuated and it stays switched until loop 1 is released again.

A directional detection can be realized accordingly with the channels 3 and 4.

## 10.2 Laying of the Loop with Directional Logic

Both loops of a directional detection must be close enough to each other so that every vehicle to be detected attenuates both loops. In this case the loops can also be laid in an interlocking way.

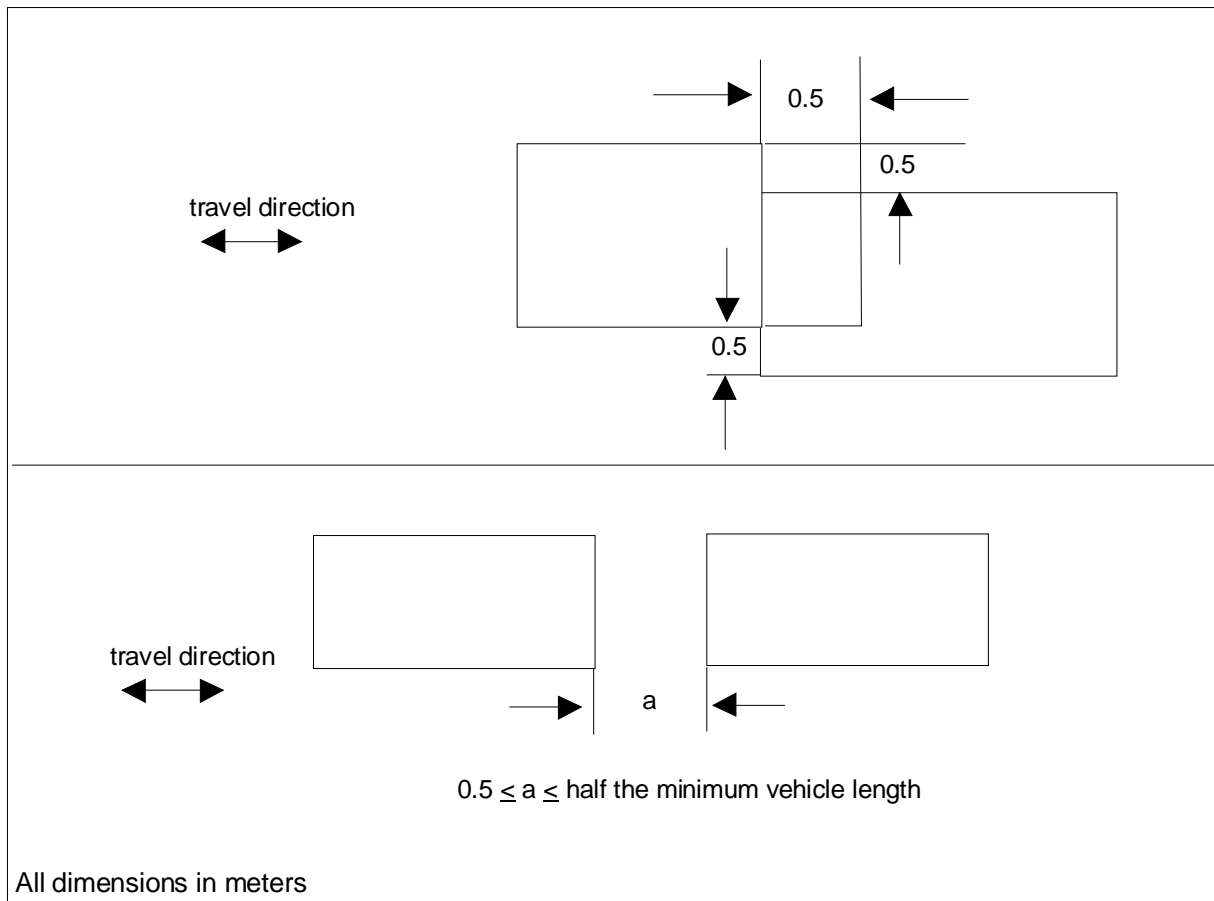

## 11 Notes on Overvoltage Protection

We recommend protecting the loop feeds for overvoltages in close proximity to the rack.

Since the induction loops may be strained neither induction-wise nor capacity-wise, here only gas release lines can be used. For this we recommend the Weiss-Electronic loop connector panel FP\_V1\_2. One loop connector panel per 4-channel detector will be required.

## 12 Notes on the Loop Wire

The requirements for the loop wire are primarily determined by mechanical and thermal exposures which especially have influence on the insulation. Furthermore, influences caused by weather (humidity) and resistance against chemicals and solvents (oil, fuel, road salt etc.) must be observed.

The mechanical exposure results from the bends caused by the loop corners. Therefore the minimum bending radius of the loop wire used must be observed. Also deformations of the loop cuts, especially in the traffic light area (hard braking and acceleration of the vehicles), must be considered. Because of this there are high requirements for the mechanic stability of the loop wire insulation (abrasion and tensile strength). Choosing an insulation material as thick as possible is advantageous.

The thermal requirements are especially high when hot casting compounds are being used ( $T_{\max}$  approx.  $250^{\circ}\text{C}$ ). When using cold casting compounds, the thermal requirement for the loop wire is predetermined by the temperature range of the loops (e.g.:  $-25^{\circ}\text{C}$  to  $+75^{\circ}\text{C}$  according to TLS<sup>1</sup> BAST<sup>2</sup>).

The insulation of the loop wire must be resistant against water absorption (deterioration of the loop's insulation resistance with wetness) and change of characteristics caused by chemical reactions (e.g. with the casting compound or the road paving).

The electric characteristic (ohmic resistance) is predetermined by the wire's material and cross-section. A flexible tinned Cu stranded wire with a cross-section of at least  $1.5 \text{ mm}^2$  must be used.

Stranded wires with an insulation based on PTFE-basis (brand names: Teflon, Polyflon, Dyneon, DIN-VDE label "5Y") have proved themselves as loop wire. This kind of insulation material fulfils the thermal requirements for hot casting (up to  $260^{\circ}\text{C}$ ), is solvent resistant, weatherproof, has a low water absorption (long-time stable insulation resistance) as well as a high abrasion and tension strength. The thickness of the insulation material should also not be lower than 1 mm. For further improvement of the mechanical characteristics, the stranded wires can be obtained with glass-fibre (no metal!) sheathing.

Insulations made of PVC, PE ( $< 120^{\circ}\text{C}$ ) and generally of silicon (Si, high water absorption and low abrasion strength) are not suited, especially for hot casting.

The TLS, BAST recommends the following cable type: TE-CU VS AWG 14EE

Weiss-Electronic offers a Teflon-insulated loop wire with glass-fibre sheathing labeled "SK".

<sup>1</sup> TLS: Technical terms of delivery of road stations

<sup>2</sup> (German) federal office for road constitution

# Loop Installation



Thank you for choosing a Weiss-Electronic GmbH quality product.  
We are glad to provide you with a product which combines a safe operating performance  
with the best possible usability.